

# After-sales Service Instructions

**Testing**

**42**

Archiv/VDT

VDT-W-420/303 B  
Ed. 2

supersedes VDT-WPP 001/4 B, suppl. 3

**Mechanical Governor**

042... - ROV... K...

**BOSCH** After-sales Service  
Automotive  
Equipment

## Contents

|      |   |
|------|---|
| Page |   |
| 2    | Tools   |
| 3    | Preadjustment   |
| 4    | Governor Testing  |
| 5    | MPC Adjustment  |
| 8    | Full-Load Adjustment  |
| 14   | Schematic Drawings<br>with parts identified by the numbers given<br>in the text |
| 17   | RQV...K... with MPC on Drive Side   |

## Tools Used (also see WA-VKF 053/1)

|   |                           |
|---|---------------------------|
| Control-rod adjustment mechanism  | 1 688 130 030             |
| Bracket for measuring the position<br>of the sliding block  | 1 682 329 038             |
| Control-rod adjustment mechanism for<br>measuring the sleeve travel   | 1 688 130 095             |
| Protractor for testing the governor   | 0 681 440 006             |
| Equipment for MPC testing,<br>consisting of: Adjustment throttle  | 1 688 130 032             |
| Pressure regulator valve for compressed<br>air with pressure gauge 0-4 bar<br>(for example, produced by<br>Kraiss & Friz, Stuttgart, No. 104) | commercially<br>available |
| Pressure gauge 0-1.6 bar,<br>quality grade 1.0, scale graduations 0.05<br>(for example, produced by Wika,<br>No. 4184)                        | commercially<br>available |

© 1975 Robert Bosch GmbH  
Automotive Equipment Division After-Sales Service  
Department for Technical Publications KH/VDT  
D-7 Stuttgart 1, Postfach 50

Questions and comments on the contents are to be  
directed to our authorized representative in your  
country

The contents are only intended for the use of the  
Bosch after-sales service organization, and may not  
be passed on to third parties without our consent.

Printed in the Federal Republic of Germany  
Imprimé en République Fédérale d'Allemagne  
par Robert Bosch GmbH

(4. 76)

## Preparations

Clamp the pump on the test bench, connect lines.

Mount the control-rod travel measuring device.

Remove the full-load stop rocker guide (2) and possibly the manifold-pressure compensator (MPC) if the governor is fitted with this part.

Remove the guide pin for the swivelling lever.

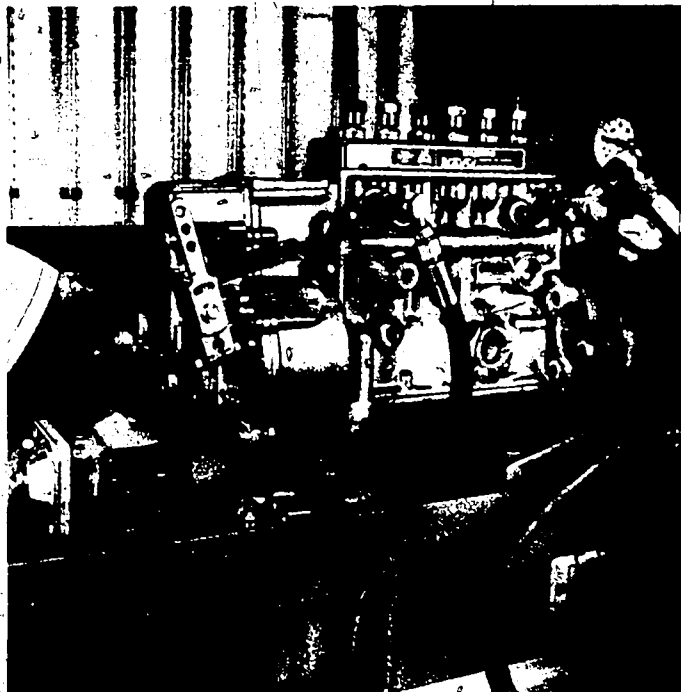

Remove the governor cover.

Remove the swivelling lever.

Remove the coupling bolt, sliding block, and adjusting pin.

Position the adjusting pin by means of the coupling bolt in the flyweight assembly.

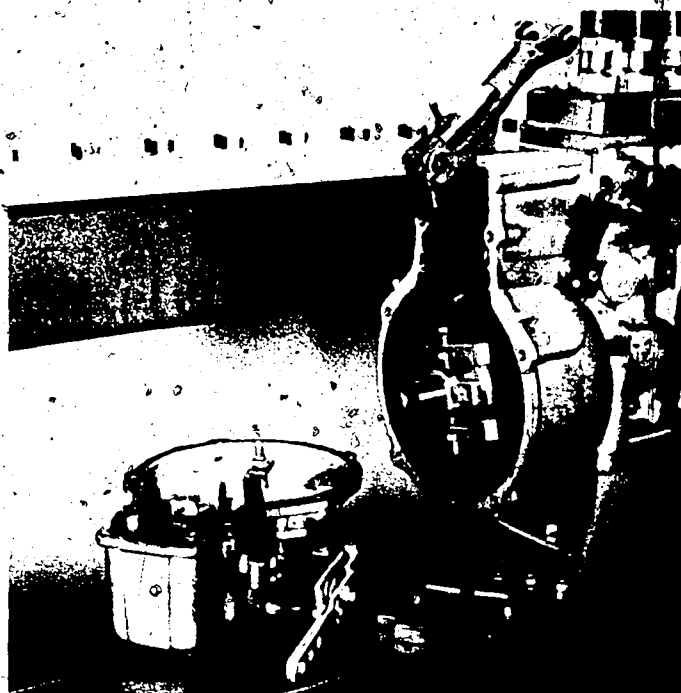

Measure the position of the sliding block  
(Use bracket 1 682 329 038.)

The nominal distance from the center of the sliding block to the housing (without seal) is  $35.0 \pm 0.2$  mm.

Pull on the adjusting pin so that the flyweights are drawn into the inner position.

In this position (without seal) the measurement device should fit snugly, i. e., with no play, into the sliding-block guide.

If necessary, change the length of the adjusting pin by turning the adjustment screw.

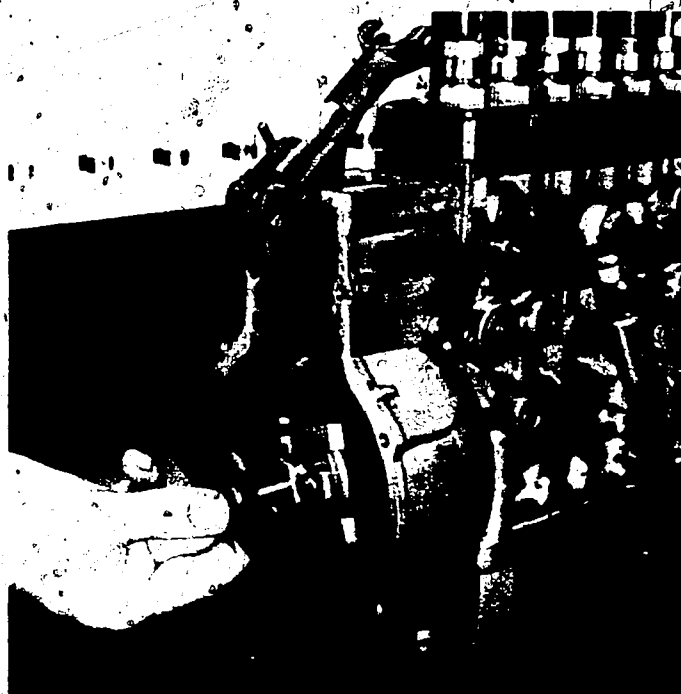

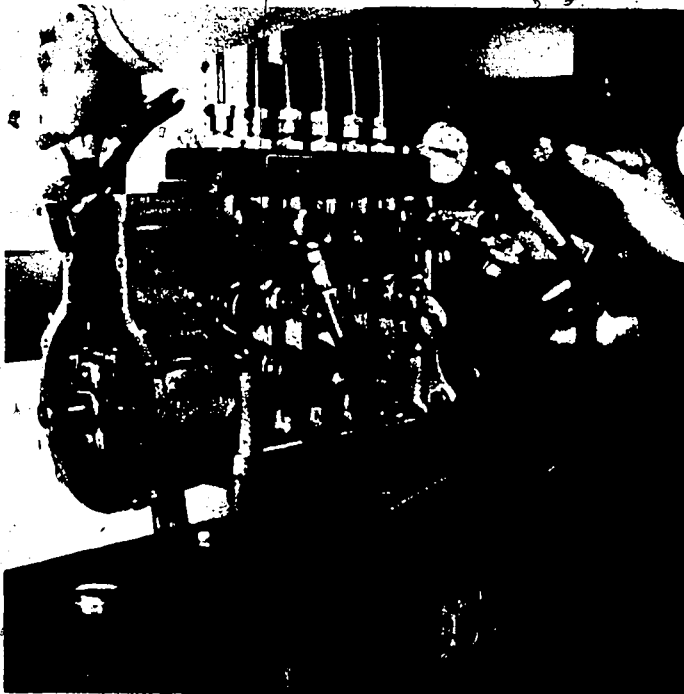

#### Check the play of the rubber buffers

- Prevent the flyweights from turning by blocking them with a screwdriver and turn the test bench flywheel in both directions.

The play measured when this is done should be 10–25.

If necessary, replace the rubber buffers.



#### Prepare the governor for measurement of the sleeve travel

Mount the fulcrum lever, sliding block, and adjusting pin.

The longitudinal play of the coupling bolt should be 1–2 mm.

Do not mount the swivelling lever.

In order to prevent the plunger and barrel assemblies from running dry, clamp the control rod at a control-rod travel of about 9 mm.

As protection, mount a temporary cover with a section that has been cut out (for example RQ or RQV).

For stabilization purposes, the sliding-block guide screw is located under the sliding block.

Fill the governor with lubricating oil.

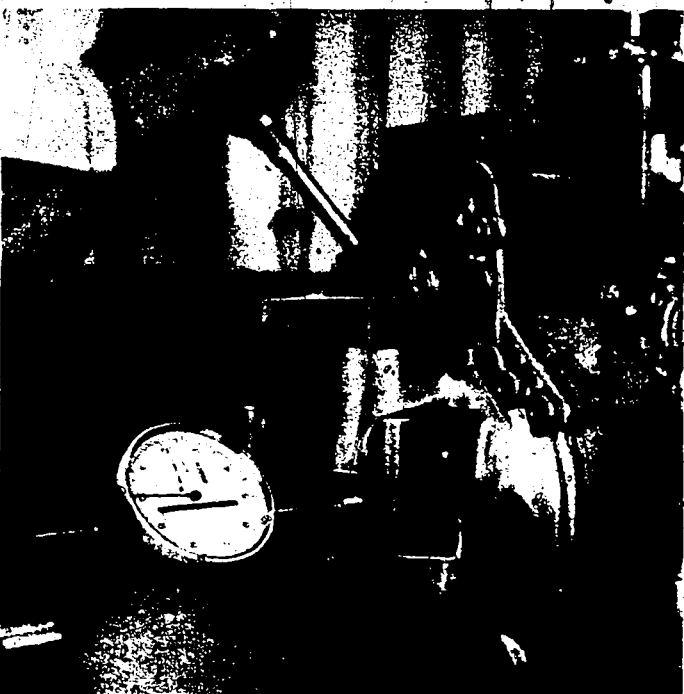

#### Measure the sleeve travel

The sleeve travel is measured using an instrument stand and a control-rod travel dial indicator.

The magnetic foot of the dial indicator is positioned against the center of the adjusting pin.

Press the governor springs over by hand (flyweights in inner position).

Prestress the dial indicator about 20 mm.

Compensate for play in the governor mechanism by a light pull on the dial indicator stem, and set the dial indicator to 0.

Set the sleeve travel according to Test Specification Sheet B, Columns 10 and 11

The most accurate possible maintenance of the specified sleeve travel is of vital importance for all later measurements!

Set the speed to the value given by the test specification sheet at which the sleeve travel is without tolerances

Set the associated sleeve travel by uniformly tightening both sets of governor springs

One notch difference is permissible

Test the remaining sleeve travel values and if necessary correct them by inserting shims, by the selection of different spring seats, or by replacing the governor springs according to the service part microfiche

Remove the instrument stand

Remove the temporary governor cover and collect the lubricating oil

**Test Specifications**

**40**

VDT-WPP 001/4 ...

Edition

Section B

| Degree of deflection of control lever | Control rod travel |           | Sliding sleeve travel |             |
|---------------------------------------|--------------------|-----------|-----------------------|-------------|
|                                       | rev/min            | mm        | rev/min               | mm          |
| approx 10                             | 100                | 6.6 - 8.0 | 0 - 70                | Start       |
|                                       | 250                | 5.0 - 6.6 | 200                   | 0.5 - 1.2   |
|                                       | 400                | 2.9 - 4.6 | 480                   | 5.2 - 4.0   |
|                                       | 550                | 1.2 - 2.6 | 800                   | 4.8 - 5.2   |
|                                       | 700                | 0         | 1270                  | 8.3         |
|                                       |                    |           | 1420                  | Finish (11) |
|                                       |                    |           | 1510                  |             |

#### Measure the position of the plate cam

Turn the control lever over so that the stop screw is not up against it

The nominal distance from the seal on the cover to the center of the pilot = **24.5 mm**.

Set the control lever to Voll (maximum fuel)

The pilot on the linkage lever is positioned at the end of the rocker guide

Set the nominal distance by placing shims under the plate-cam stop

Example of measurement

With a pilot 6 mm in diameter, and with a gauge 6 mm thick, the adjustment distance is 27.5 mm from the gauge to the pilot

This distance is derived as follows: standard distance (24.5) plus thickness of gauge (6) minus pilot diameter (3) = the adjustment distance of 27.5 mm

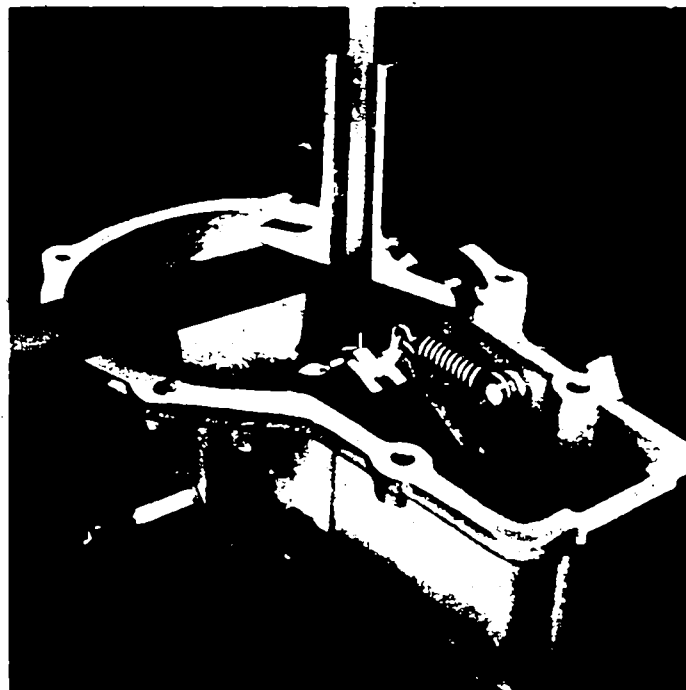

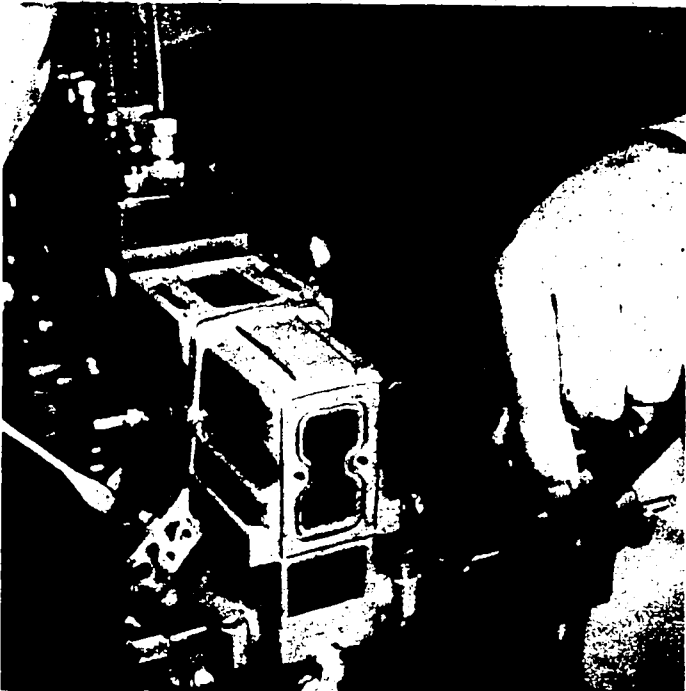
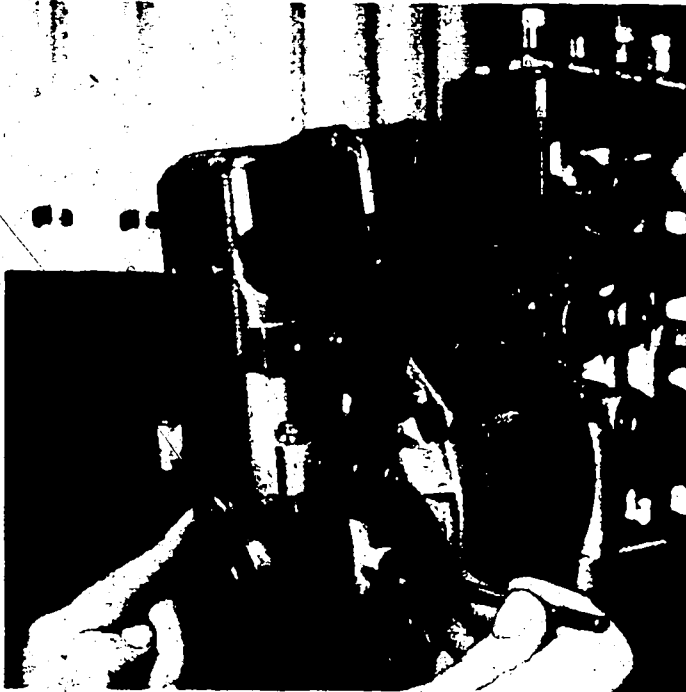

### Fitting the governor cover

Release the clamping mechanism at the control-rod travel measuring device.

Fit the swivelling lever in place.

Fit the governor cover together with a seal **but do not bolt it in place.**  
The longer part of the guide block points upward.

Align the holes in the swivelling lever with the holes in the governor cover using a pointed instrument (for example a marking tool) and insert the guide pin into the governor.

Fit the screw plugs for the guide pin.

Bolt the governor cover in place.

Fill the governor with lubricating oil.

9 Attach the protractor.

### Checking the play in the governor parts

Using the control lever, set the control-rod travel to 2 mm and clamp the control rod in place.

Press the governor springs over by hand.

The control lever play must not exceed 2 mm.  
When carrying out these steps do not press the sprung strap over.

Release the control-rod travel measuring device.

### Setting the fine adjustment

10 Set the speed to about 100 rev/min.

Using the control lever, set the control-rod travel to about 10 mm and clamp the control lever.

Release the lock nut for fine adjustment (4) and unscrew the adjustment screw as far as the stop.

#### Caution:

**when reading the control-rod travel values do not press on the adjustment screw!**

Set the dial indicator to 0.

Turn the adjustment screw for fine adjustment  $\frac{1}{2}$  turn inward and observe the dial indicator.

When turning the adjustment screw no longer results in a change in the control-rod travel, the total fine adjustment range can be read on the dial indicator.

11 Turn the adjustment screw back  $\frac{1}{2}$  of the fine adjustment range read from the dial indicator and lock it in this position.

### Setting the protractor

Set the speed to 0 rev/min.

Set the dial indicator on the control-rod travel measuring instrument to 0 when the control rod is in the shut-off ("Stop") position.

Press the governor springs over by hand (flyweights in the inner position).

Move the control lever slowly from shut-off toward the maximum fuel ("Voll") position. The control lever is positioned at 0 when the dial indicator just leaves its zero mark.

Set the protractor to the zero position determined.

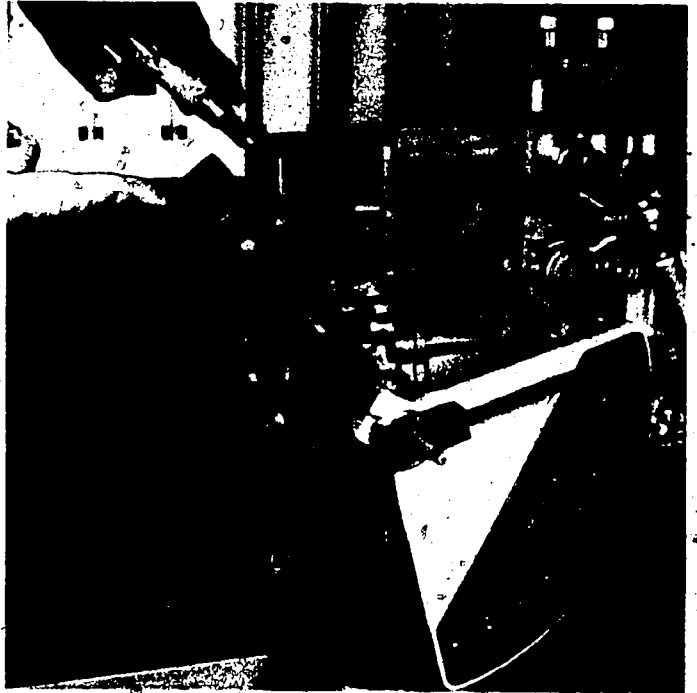

12

### Setting the lever ratio

#### Caution:

do not set the control lever to a control-rod travel of more than 21 mm!

Set the speed according to the top line of the test-specification sheet, Section B, Column 2, and at the same time readjust the control lever.

Adjust the control lever so that the associated control-rod travel given in Column 3 is reached.

Read the angle shown on the protractor and record this value because it is required for later measurements, for example Fig. 19.

If the control-rod travel given in Section B, Column 3, is not reached, or if the angle (Column 1) differs by more than  $\pm 3^\circ$  from the specified value, i.e., in event of larger deviations, the position of the sliding block (Fig. 3) must be changed. When doing this,  $\frac{1}{2}$  turn (shorter adjusting pin) means about 2.25 mm less control-rod travel.

Correct for small deviations by means of shims under the plate cam stop. In this case, reducing the thickness of the shims by 0.15 mm results in about 1 mm less control-rod travel.

**The prestress of the governor springs must not be changed!**

## B. Governor Settings

| Upper rated speed                     |         |                       | Intermediate rated speed              |         |
|---------------------------------------|---------|-----------------------|---------------------------------------|---------|
| Degree of deflection of control lever | rev/min | Control rod travel mm | Degree of deflection of control lever | rev/min |
| 1                                     | 2       | 3                     | 4                                     | 5       |
| approx. 68                            | 1150    | 15,0 - 18,2           | -                                     | -       |
|                                       | 1380    | 0 - 1,5               |                                       |         |
| approx. 62                            | 1100    | 15,0 - 17,8           | -                                     | -       |
|                                       | 1150    | 10,2 - 13,8           |                                       |         |
|                                       | 1200    | 5,0 - 10,0            |                                       |         |
|                                       | 1250    | 0 - 5,6               |                                       |         |
|                                       | 1320    | 0                     |                                       |         |

Torque control travel a \_\_\_\_\_ mm

13

1

# Test Specifications

# 40

VDT-WPP 001/4 ..

## Section B

.. Edition

| Lower rated speed<br>Degree of deflection of control lever | Control rod travel |           | Sliding sleeve travel<br>Torque-control-travel |             |
|--|--------------------|-----------|--|-------------|
|  | rev/min            | mm        | rev/min  | mm          |
| 7  | 8                  | 9         | 10   | 11          |
| approx. 10   | 100                | 6,6 - 8,0 | 0 - 70   | Start       |
|  | 250                | 5,0 - 6,6 | 200  | 0,5 - 1,2   |
|  | 400                | 2,9 - 4,6 | 480  | 5,2 - 4,0   |
|  | 550                | 1,2 - 2,6 | 800  | 4,8 - 5,2   |
|  | 700                | 0         | 1270   | 8,3         |
|  |                    |           | 1420   | Finish (11) |
|  |                    |           | 1510   |             |



### Testing speed regulation

#### Upper nominal speed

Test specification sheet, Section B, Columns 1-3.

Test the governor according to the data given in the test specification sheet with increasing and decreasing speeds.

The control-rod travel difference must not be more than 2 mm.

If tolerances are exceeded, adjustment made according to Figs. 3, 6, 8, 11, 12, or 13 are incorrect.

**The prestress of the governor springs must not be changed!**

#### Lower nominal speed

Test specification sheet, Section B, Columns 7-9.

Move the control lever back until the specified control-rod travel values are reached at the speeds given.

14 If tolerances are exceeded, adjustments made according to Figs. 3, 6, 8, 11, 12, or 13 are incorrect.  
**The spring tension must not be changed!**

### Fitting the full-load stop

Adjust the stop lug so that it is positioned parallel to the base plate.

Control lever to shut-off.

Fit the full-load stop with seals on the governor housing.

As a result of simplifications made in design and adjustments, the sequence of testing steps starting with Fig. 15 has been partially changed.

The same applies for combinations with an MPC on the drive side.

(Information on this point is given on pages 16 and 17.)

### Testing the manifold-pressure compensator (MPC)

Test specification sheet, Section D.

Connect the pressure regulator to the **lower** connector on the adjustment throttle, and connect the MPC to the **upper** connector on the throttle.

adjustment screw "a" (white, lower) is used to set the pressure.

adjustment screw "b" (black, upper) is used for leakage tests.





### Testing the MPC for leaks

Set the charge-air pressure to 1.0 bar at adjustment screw "a" on the adjustment throttle; close adjustment screw "b" and shut off the air supply. The pressure gauge must not register a pressure drop.

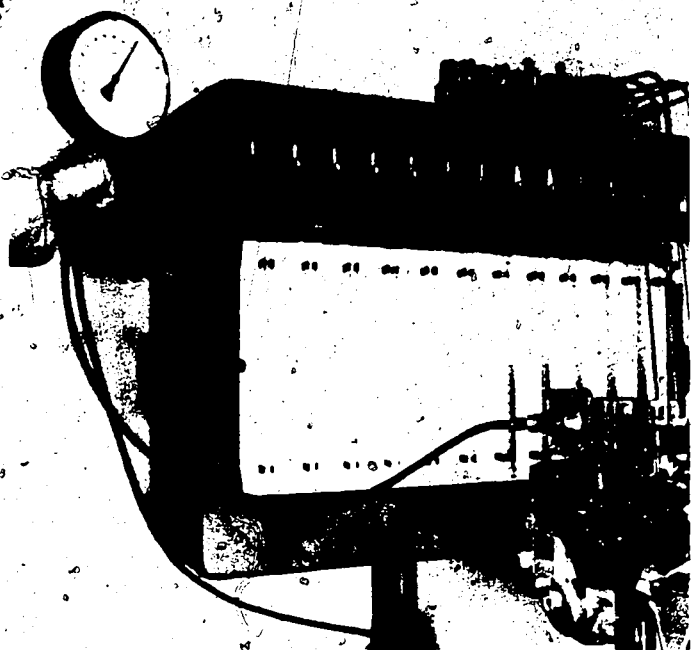

17

### Checking the MPC adjustment

Increase the pressure of the compressed air slowly from about 0 bar and observe the full-load stop screw (1) in the MPC.

At the charge-air pressure given in the test specification sheet, Section C, Column 1, the full-load adjustment screw must be positioned firmly at the limit stop.

If necessary, reduce the tension on the diaphragm spring in the MPC by turning the notched nut (15).

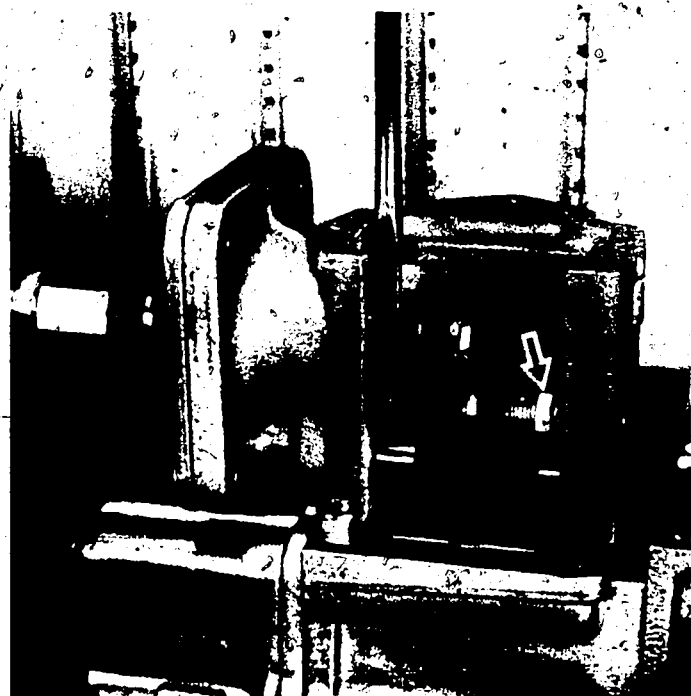

18

### Setting the rocker

Test specification sheet, Section B, Columns 10 and 11 or Section 6, Column 8.

**Applies only for full-load stop with "bent" rocker guide track (Fig. 19).**

If the governor is fitted with an MPC, set the charge-air pressure to the maximum value (test specification sheet, Section C, Column 1).

Set the speed to the value given in the box (test specification sheet, Section C, Column 8 or Section B, Column 10) and at the same time readjust the control lever.

Clamp the control lever at the angle determined according to Fig. 13.

Let the rocker traverse the rocker guide track.

Change the adjustment screw (5) on the rocker and observe the dial indicator.

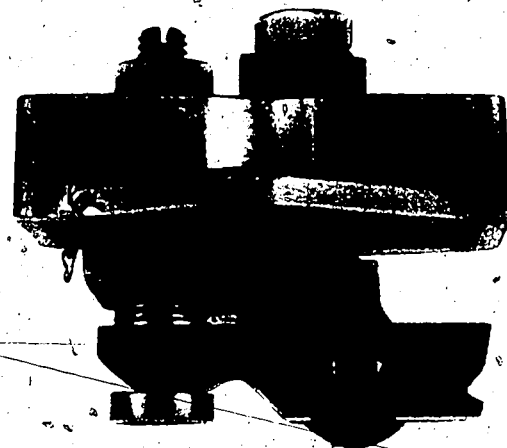

19

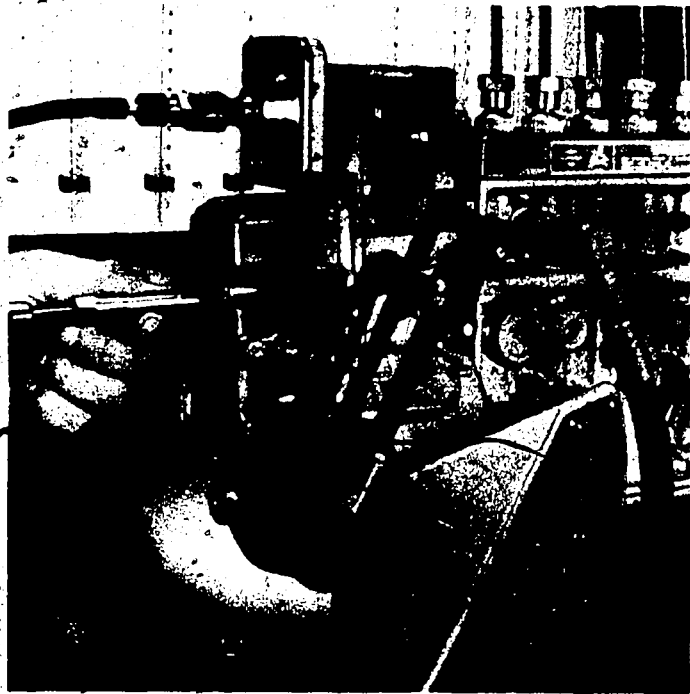

- Find the point of reversal and set it. The largest possible control-rod travel should be set at the rocker in the range in which the control-rod travel first increases and then decreases with the same direction of adjustment.
- Secure the adjustment screw on the rocker with the lock nut.

#### Checking the rocker adjustment

- Increasing and decreasing the adjustment speed (test specification sheet, Section B, Column 10 or Section C, Column 8, value given in box) results in a smaller control-rod travel.
- The maximum control-rod travel must be measured at exactly the speed given in the box.
- Set the speed to exactly the value given in the box.

20

#### Applies only for full-load stop with straight rocker guide track (Fig. 21).

If the governor is fitted with an MPC, set the charge-air pressure to 0.

Operate the pump at below the idle speed.

Slowly increase the speed and by repeatedly moving the control lever slowly forward determine the speed at which the rocker moves forward under the stop cam to "Start".

**This switching operation should take place at 50–100 rev/min below the idle speed.**

Turning the rocker adjustment screw (5) to the right shifts the switching point to a higher speed.

Secure the rocker adjustment screw with a lock nut.

With an MPC, set the charge-air pressure to the maximum value (test specification sheet, Section C, Column 1).

21

Set the speed (test specification sheet, Section B, Column 10, value given in box) exactly and at the same time readjust the control lever.

Clamp the control lever at the angle determined according to Fig. 13.

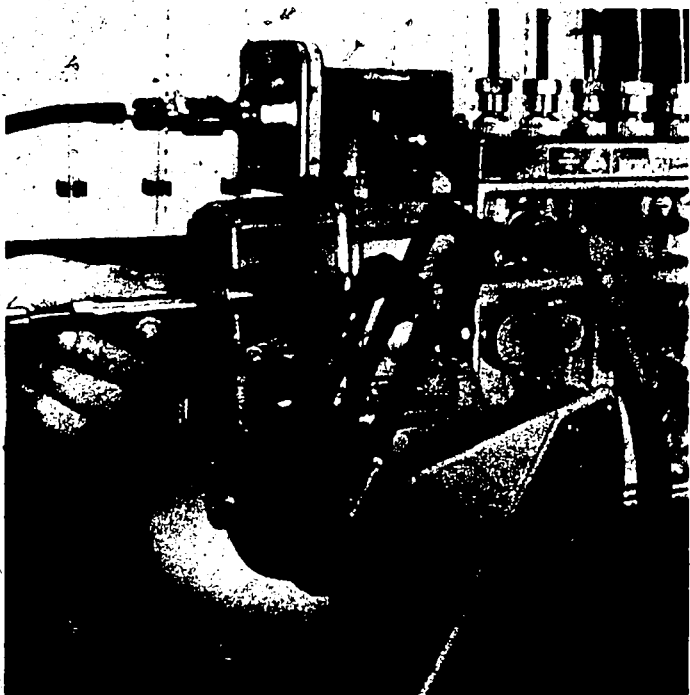
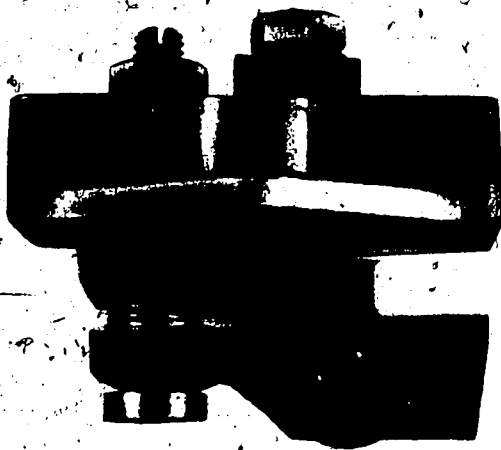

22

### Setting full-load control-rod travel

Set the control-rod travel (test specification sheet, Section B, Column 11, value given in box) at the full-load stop screw (1).

Lock the full-load adjustment screw after every adjustment.

After the adjustment of the full-load control-rod travel, the test (set rocker) starting with Figs. 19 and 20 or Figs. 21 and 22 must be repeated.

23

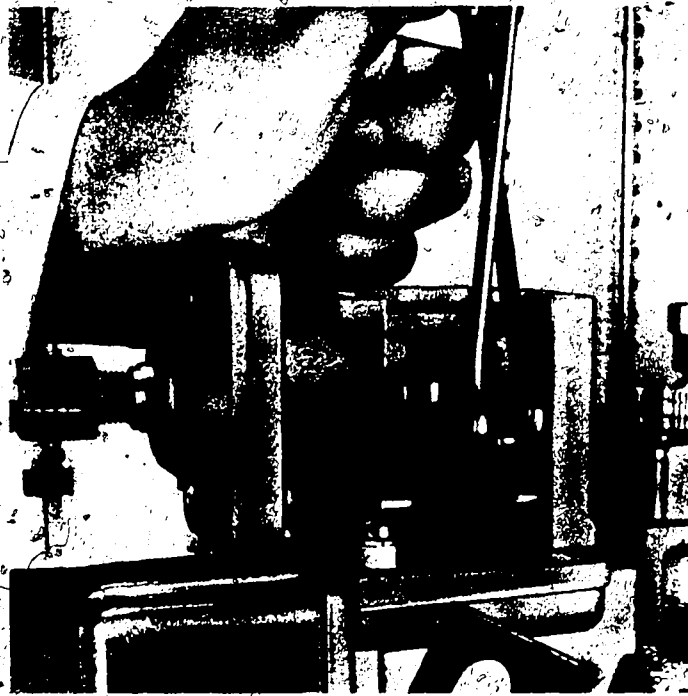

### Testing the torque control

Test specification sheet, Section B, Columns 10 and 11.

With an MPC, set the charge-air pressure to the maximum value (test specification sheet, Section C, Column 1).

Set the speed to the values specified under "Torque Control" in the test specification sheet and read the control-rod travel values.

The control-rod travel values specified can only be reached if the adjustments described above (Figs. 3, 6, 7, 8, 11, 12, and 13) have been made with the greatest accuracy.

Turn the adjustment screw (8) at the stop lug until the control-rod travel values can be reached as exactly as possible at the corresponding speeds.

Turning this screw inward increases the control-rod travel values at high speeds and reduces these values at low speeds.

As a result, the rocker and full-load adjustment must be repeated!

Repeat the tests described starting with Fig. 19.

The rocker adjustment (Fig. 14), the full-load adjustment (Fig. 23), and the torque control (Fig. 24) affect each other!

The corrections become smaller and smaller as the nominal values are approached.

After every readjustment secure the adjustment screws with lock nuts!

24

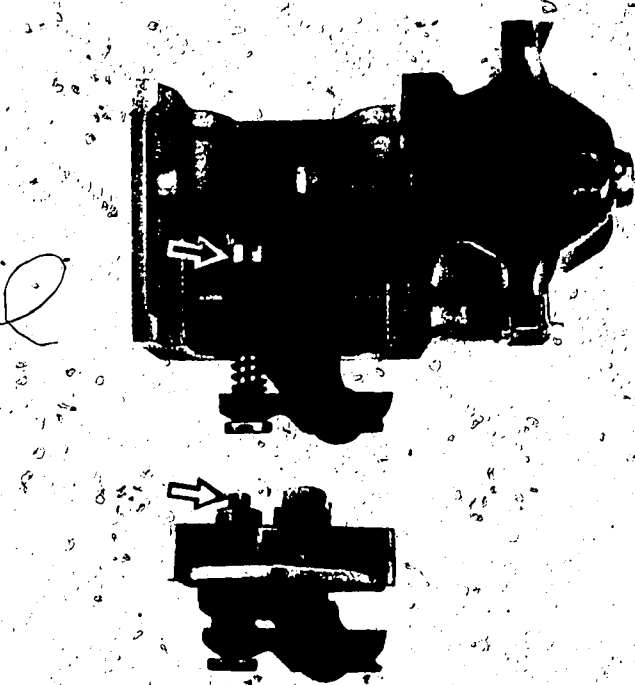



### Testing full-load delivery

Test specification sheet, Section C, Columns 1, 2 and 4, 5.

With an MPC, use maximum specified charge-air pressures for the tests.

The specified full-load delivery values should not be corrected at the governor full-load stop (full-load, delivery, torque control, and start locking affect each other).

Small deviations can be corrected at the fine adjustment screw (4) (about  $\pm 0.2$  mm control-rod travel).

Larger deviations must be corrected on the basis of uniform fuel delivery (Section A, value given in box).

25

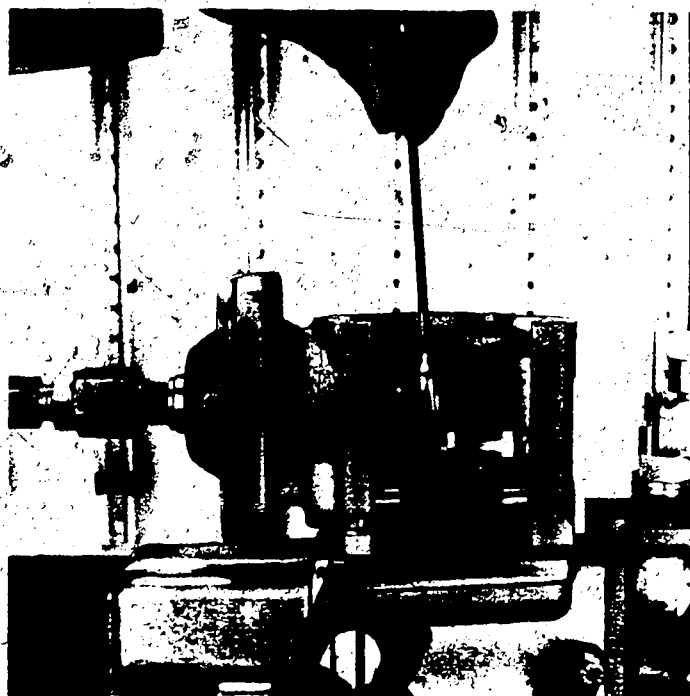

### Setting intake volume

Test specification sheet, Section C – values with 0 bar data.

Control lever to maximum fuel ("Voll") – pressure 0 bar.

Set the fuel delivery given in the test specification sheet, Section D, with a charge-air pressure of 0 bar, using the stop nuts (14) at the MPC.

26

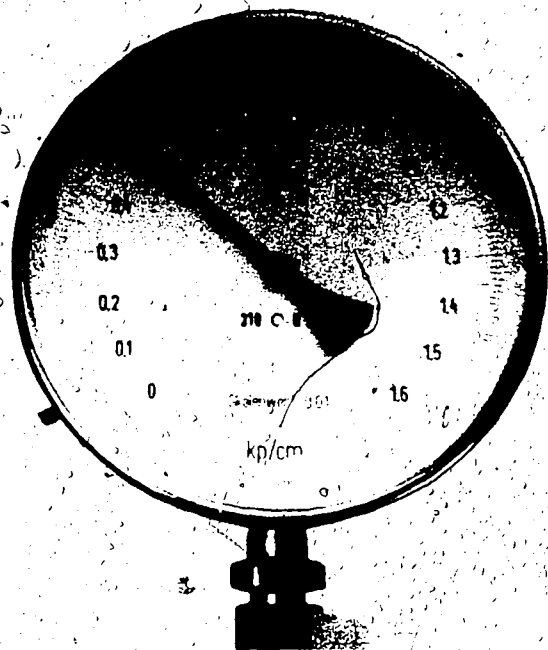

### Testing diaphragm and diaphragm spring in MPC

Test specification sheet, Section D.

Set the speed specified.

#### Test made with falling pressure = control-rod-travel decrease

Set the charge-air pressure to the maximum value (test specification sheet, Section C) and set the dial indicator to 0.

Or

#### test made with rising pressure = control-rod-travel increase

At a charge-air pressure of 0 bar set the dial indicator to 0.

27

Set the charge-air pressure to the value specified under "**Adjustment**" in the test specification sheet.

Set the associated control-rod travel at the notched nut (15) on the MPC.

Set the charge-air pressure to the value specified under "**Measurement**" in the test specification sheet and read the dial indicator.

If the control-rod travel is outside the tolerance, the diaphragm or the diaphragm spring in the MPC must be replaced.

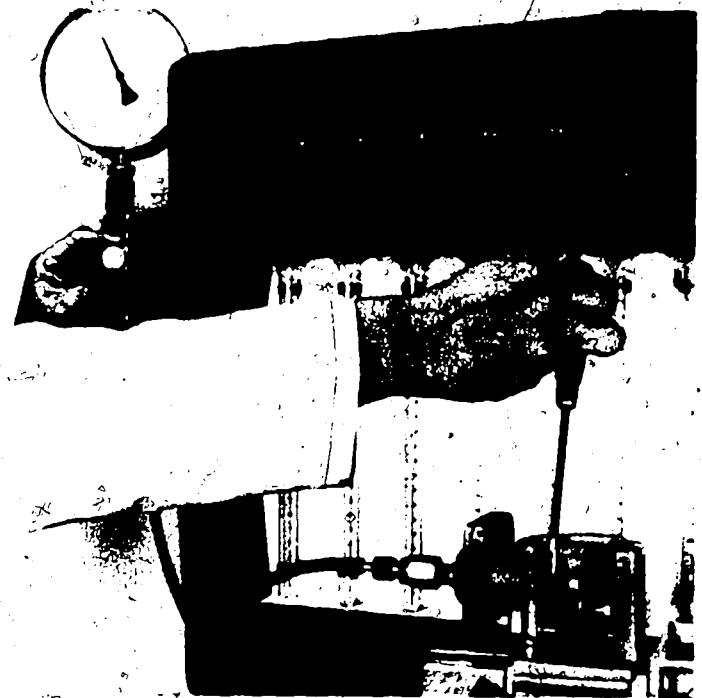

28

#### Setting the speed limitation

Test specification sheet, Section C, Column 3.

Remove the protractor.

Turn the control lever over or install the original control lever.

With an MPC, set the charge-air pressure to the maximum value.

Increase the speed and at the same time readjust the control lever.

At the speed specified in the test specification sheet, Section C, Column 1, set the dial indicator to 0.

Set the speed given in Column 3.

Control lever at limit stop.

Set the stop screw so that the dial indicator shows a decrease of about 1 mm in the control-rod travel.

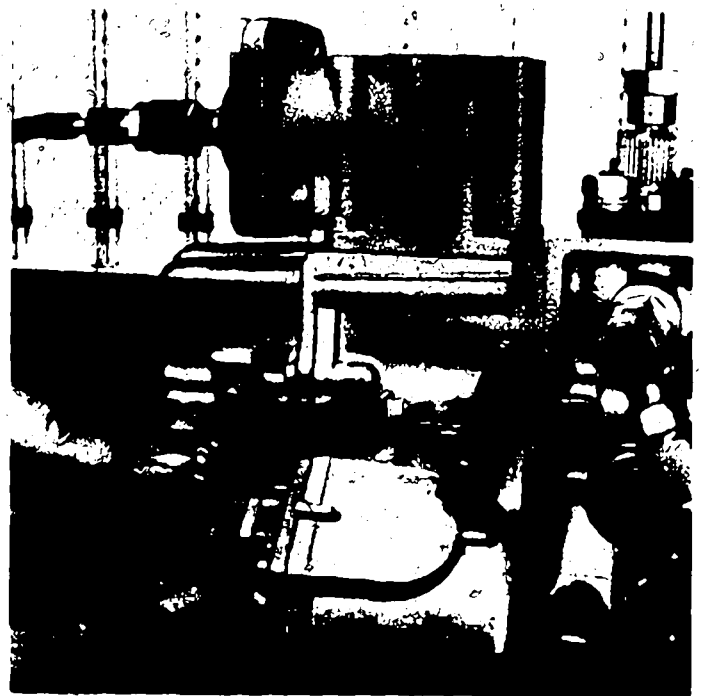

29

#### Setting the idle and shut-off stop

This applies only for governors without a stop lever.

#### Setting the shut-off stop screw

Set speed to 0 rev/min.

Control lever to shut-off ("Stop").

Release the shut-off stop screw and set the dial indicator to 0.

Set a control-rod travel of about 0.5 mm at the shut-off stop screw and secure the stop screw with a lock nut.



30

List of parts mentioned in text

- 1 Full-load stop screw
- 1a Full-load stop
- 2 Rocker guide
- 3 Rocker
- 4 Fine adjustment
- 5 Rocker adjustment screw
- 6 Sliding block
- 7 Swivelling lever
- 8 Adjustment screw
- 9 Full-load stop (complete)
- 10 Control rod
- 11 Strap
- 12 Fulcrum lever
- 13 Flyweight assembly
- 14 Stop nuts
- 15 Notched nut

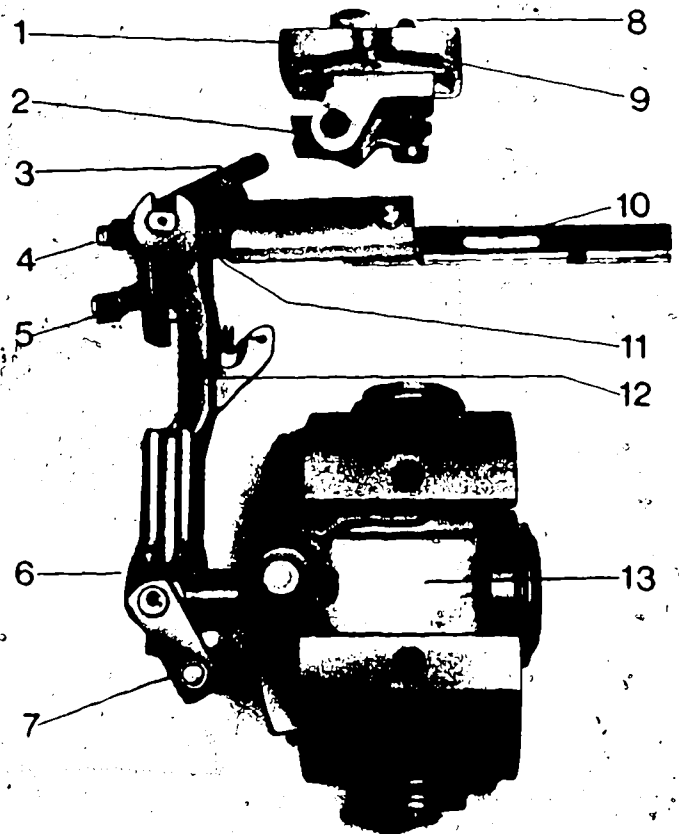
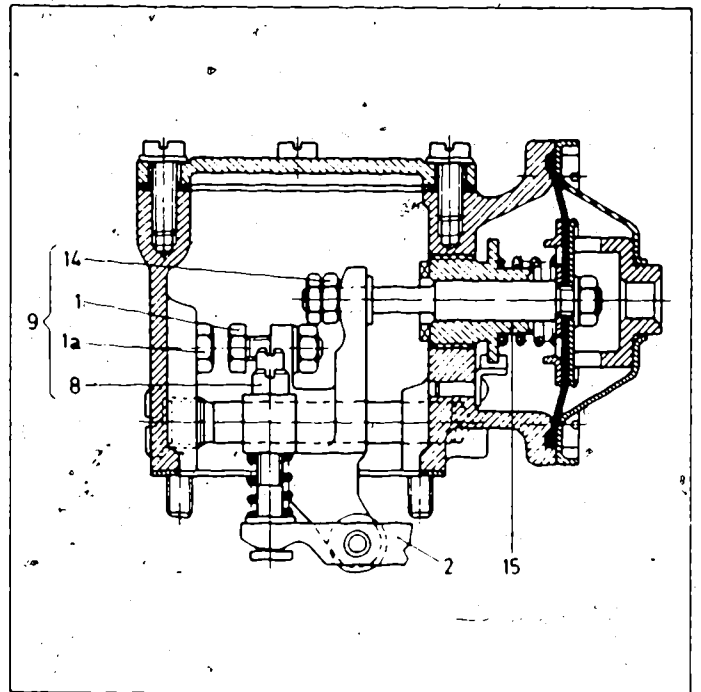

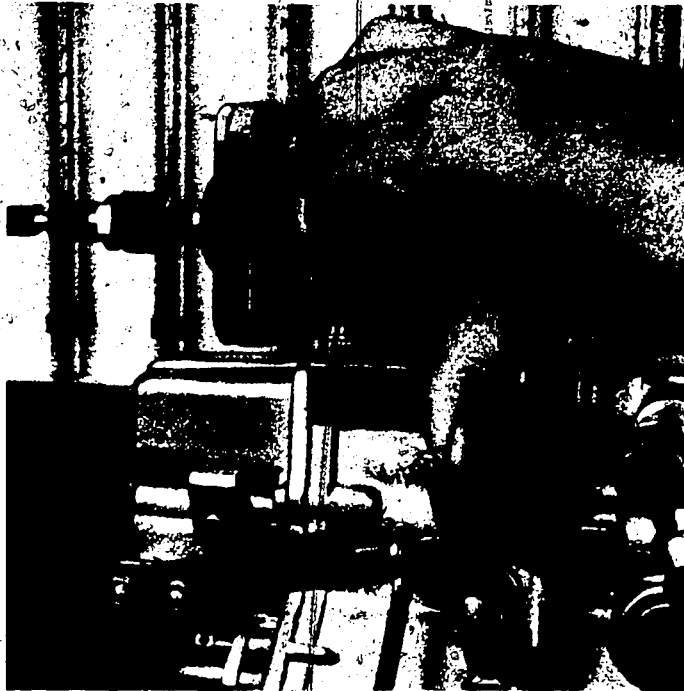

31

Applies only for governors with a stop lever.

#### Setting Idle

Set the speed according to the test specification sheet, Section C, Column 6.  
The control lever is positioned against the idle stop.

Adjust the stop screw until the specified fuel delivery is reached.  
Secure the stop screw with a lock nut.

#### Setting the shut-off stop

Set speed to 0 rev/min.  
Pull the shut-off lever to "Stop".  
Release the shut-off stop screw and set the dial indicator to 0.

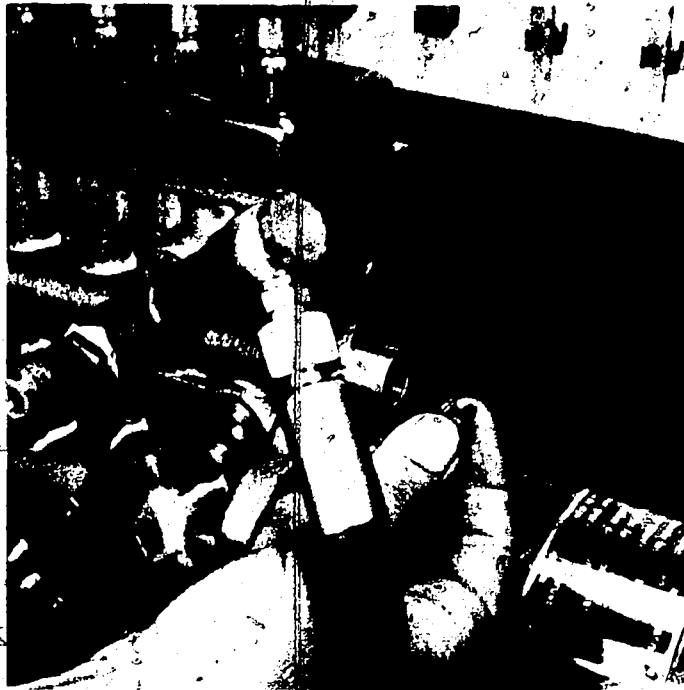

32

Set about 0.5 mm of control-rod travel at the shut-off stop screw and secure the stop screw with a lock nut.

#### Setting the starting fuel delivery

Test specification sheet, Section C, Column 6.

Remove the control-rod travel measurement instrument.  
Control lever at limit stop.  
Set the speed according to the test specification sheet.

Limit the starting fuel delivery using the stop screw at the control rod sealing cap.

Replace all covers with new seals.

Remove the pump from the test bench and lead-seal it.

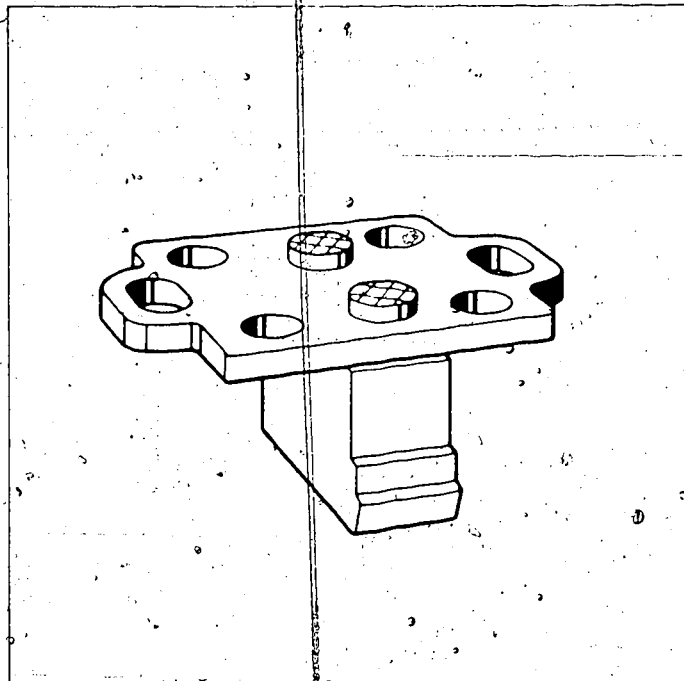

33

#### Simplified full-load stop

The full-load stop shown in Fig. 19 has been modified in some of the governors as shown in Fig. 33. As a result, the following applies:

The adjustment of the horizontal position of the stop is omitted and therefore the correction of the torque control is also omitted.

The full-load control-rod travel, and thus the full-load delivery, are set by shifting the stop in the recess in the governor housing.

**RQV . . K . . governor with an MPC on the drive side results in an additional combination:**

In this case, the full-load delivery is adjusted by the stop screw at the elbow lever in the MPC. When operating under load, full-load delivery values are set with the adjustable stop lug (Fig. 34) in the governor housing. The stop screw in the MPC housing is then set to the full-load control-rod travel + 0.5 mm.

The testing sequence, therefore – presented briefly – is as follows (using Test Specification Sheet SCA 11.0 p as an example):

- 0.7 bar n = 850 rev/min  
= full-load at stop lug.
- 0.7 bar n = 1100 rev/min  
P = full-load at stop lug (check).
- 0 bar n = 500 rev/min  
= full-load at elbow lever in MPC.
- 0.7 bar n = 1100 rev/min  
= full-load control-rod travel + 0.5 mm at stop screw in MPC housing.

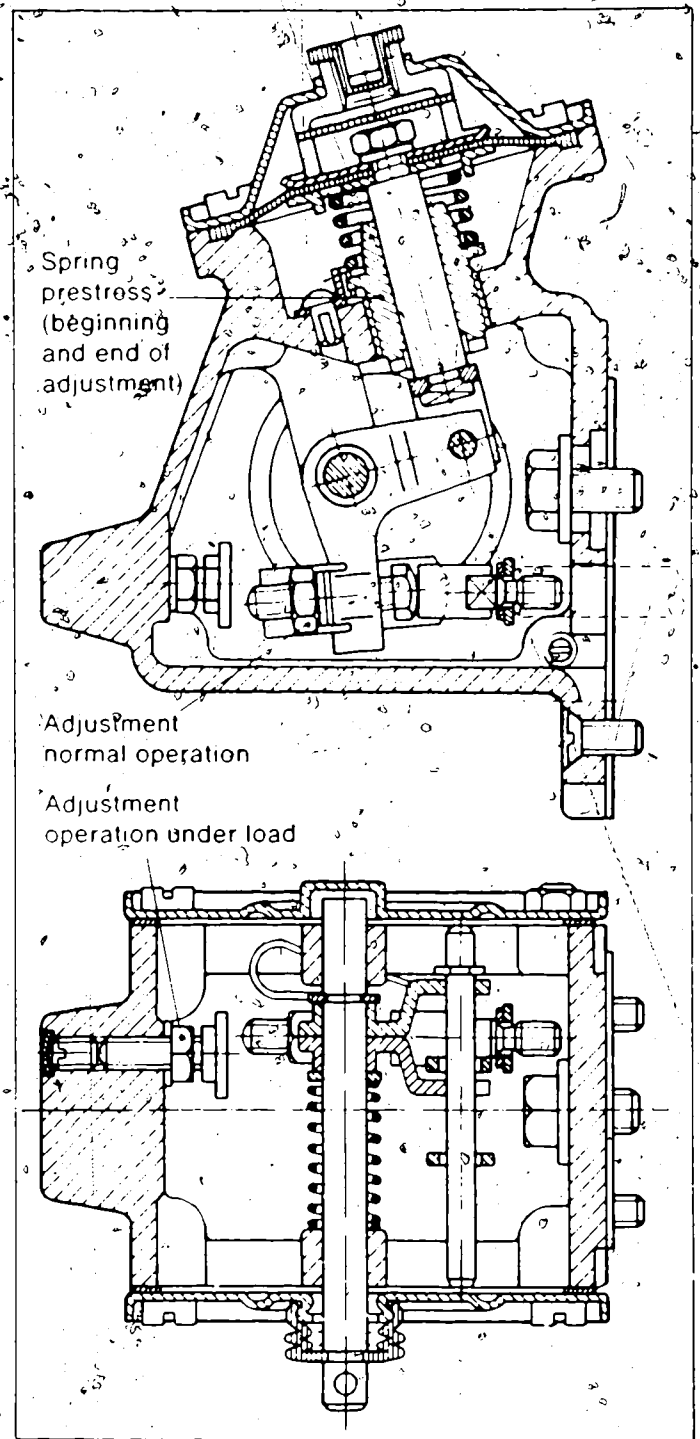



# After-sales Service Instructions

**Testing**

**42**

VDT-W-420/303 En  
Suppl. 1  
Ed. 1

**RQV..K..Governor**

with Manifold Pressure Compensator  
(MPC) on the drive side

**BOSCH** After-sales Service  
Automotive  
Equipment

B1

© 1978 Robert Bosch GmbH  
 Automotive Equipment - After-sales Service  
 Department for Technical Publications KH/VDT  
 Postfach 50, D-7000 Stuttgart 1

Please direct questions and comments concerning the contents to our authorized representative in your country.

This publication is only for the use of the Bosch after-sales service organisation, and may not be passed on to third parties without our consent.

Printed in the Federal Republic of Germany.  
 Imprimé en République Fédérale d'Allemagne  
 par Robert Bosch GmbH.  
 (6. 78)

This Supplement renders page 17 of VDT-W-420/303 invalid; the latter is replaced by the following expanded text:

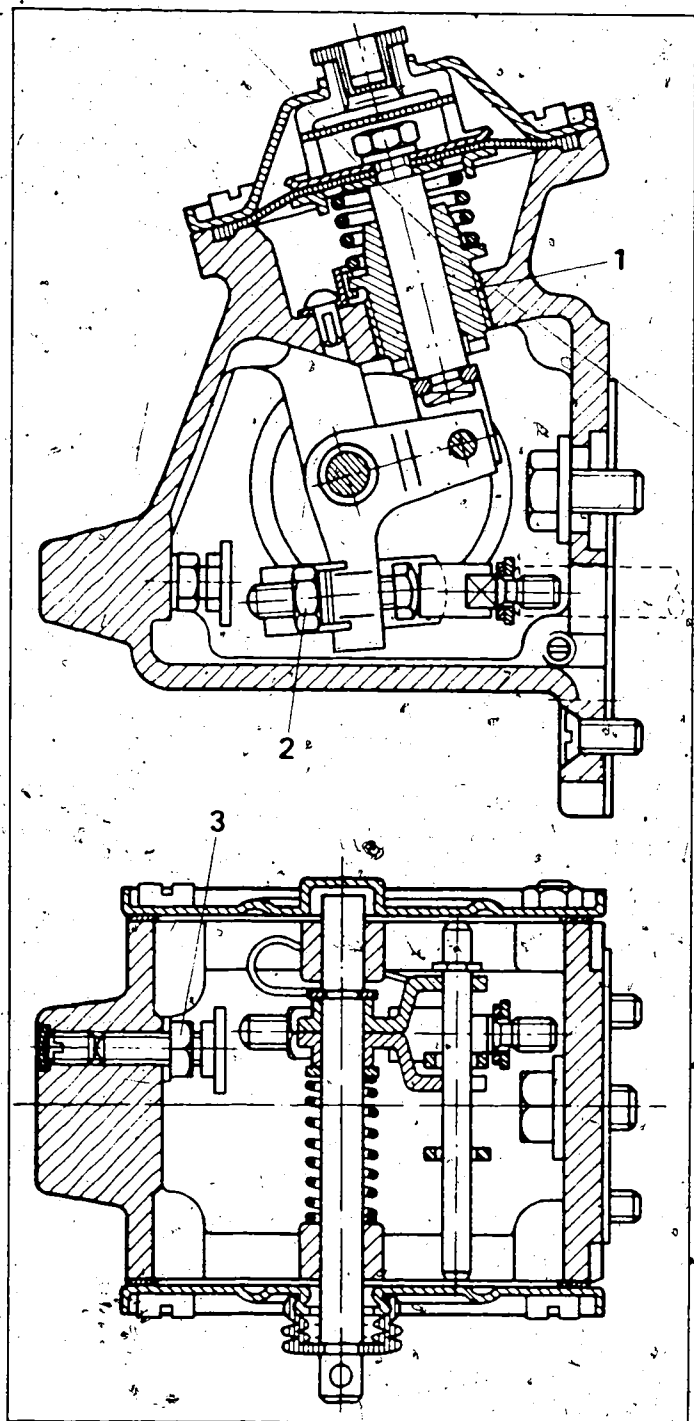

**RQV..K.. Governor with an MPC on the drive side**  
 results in an additional combination:

In this case, when the pressure charger has not yet built up enough pressure for the MPC to respond, the full-load delivery is taken up by the stop screw of the elbow lever in the MPC. When the pressure charger is delivering sufficient pressure for the MPC to respond, full-load delivery values are set with the adjustable stop lug (Fig. 3) in the governor housing. The stop screw in the MPC housing is then set to the full-load control-rod travel + 0.5 mm.

In accordance with the above test instructions the testing sequence from Fig. 12 onwards is briefly as follows: (e.g. SCA 11.0 p)

1. Measure the control-rod travel using the control-rod setting device 1 688 130 095 (EFEP.565), magnet and 30 mm (1/10) dial indicator. Fabricate clamping piece as shown in sketch and fasten to the end of the control rod (Fig. 4). Assemble control-rod setting device and apply magnet to clamping piece.

**Caution!**

The control lever 0° position is the point at which the control-rod travel dial indicator just leaves the zero position.

2. Set the lower nominal speed. Test-specification sheet, Section B, Columns 7...9. The specified control-rod travel values must be reached. See notes on Fig. 14 (VDT-W-420/303). The MPC is taken off, or the stop screw on the elbow lever in the MPC is removed so that the control rod is exposed. Carry out governor friction test with increasing and decreasing speed. Check control rod for freedom of movement.

- 1 = Spring prestress (beginning and end of adjustment)
- 2 = Adjustment, without pressure charger operating fully
- 3 = Adjustment, with pressure charger operating fully, + 0.5 mm control-rod travel

3. Set upper nominal speed.  
Test-specification sheet, Section B, Columns 1 ... 3.  
See notes on Fig. 13 in VDT-W-420/303. Set 12.7 mm control-rod travel at full-load stop (Fig. 3). Set speed regulation at a speed of 1135 ... 1145  $\text{min}^{-1}$  at the speed stop screw. Replace MPC, if removed.

Fig. 2 Enlarged lug for full-load stop.

- a = lower edge ( $n = 850 \text{ min}^{-1}$ ; adjust with lug and rocker)
- b = lower surface ( $n = 600 \text{ min}^{-1}$ ; adjust with rocker)
- c = lower notch ( $n = 1100 \text{ min}^{-1}$ )

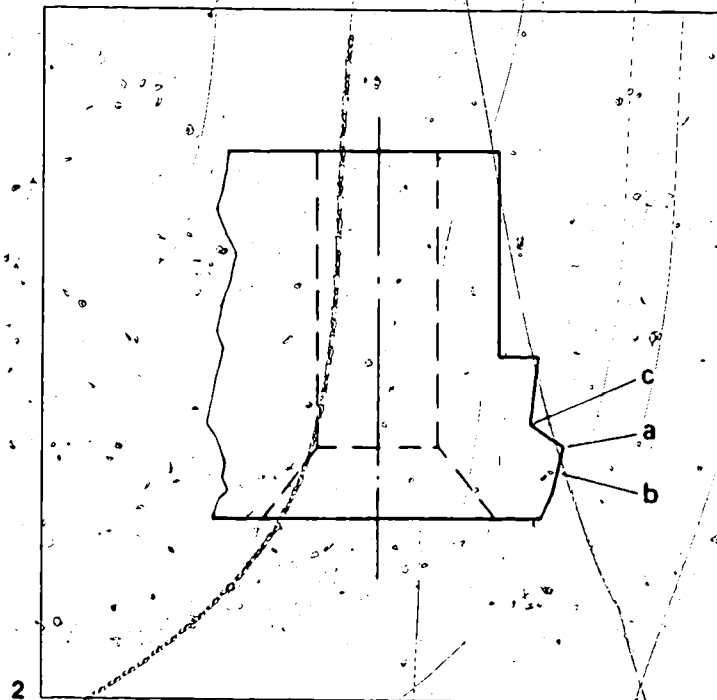

4. Set rocker.  
Test-specification sheet, Section C, Column 8.  
When speed drops from 850  $\text{min}^{-1}$  to 700  $\text{min}^{-1}$  additional control-rod travel of 0.1 mm, i. e. 12.8 mm, and from 700  $\text{min}^{-1}$  to 600  $\text{min}^{-1}$  a further additional 0.1 mm of control-rod travel, i. e. 12.9 mm, must be reached (in all, 0.2 mm additional control-rod travel). Correct at the adjusting screw of the rocker (Fig. 3).

**Caution!**

- Always reset full-load stop (Fig. 3) to 12.7 mm control-rod travel at speed of 850  $\text{min}^{-1}$ .
- Press starting button on the MPC. Measure starting control-rod travel (approx. 21 mm).
- Set speed to 1100  $\text{min}^{-1}$ . Control-rod travel of 13.5 mm must be reached.
- Set full-load control-rod travel plus 0.5 mm at the stop screw in the MPC housing (text of Fig. 34 in VDT-W-420/303) at speed of 1100  $\text{min}^{-1}$  and 0.7 bar.

5. Set intake volume.  
Test-specification sheet, Section C, Columns 4, 5.  
At a speed of 500  $\text{min}^{-1}$  (approx 11.65 mm control-rod travel) set the specified volume at the stop screw of the elbow lever (Fig. 1).

6. Test MPC.  
Test-specification sheet, Section D.  
At a speed of 850  $\text{min}^{-1}$ , 0.40 ... 0.42 bar, 12.7 + 0.1 mm control-rod travel, beginning of adjustment.  
0.20 ... 0.24 bar, 11.65 + 0.1 mm control-rod travel check-measurement.  
If these values are not reached, correct the spring prestress at the notched nut (Fig. 1).

7. Test MPC for leaks, see Fig. 17 in VDT-W-420/303.

8. Test starting function. Position control lever vertically and press starting button on the MPC. The starting fuel delivery as per Test-specification sheet, Section C, Columns 6 ... 7 must be reached.

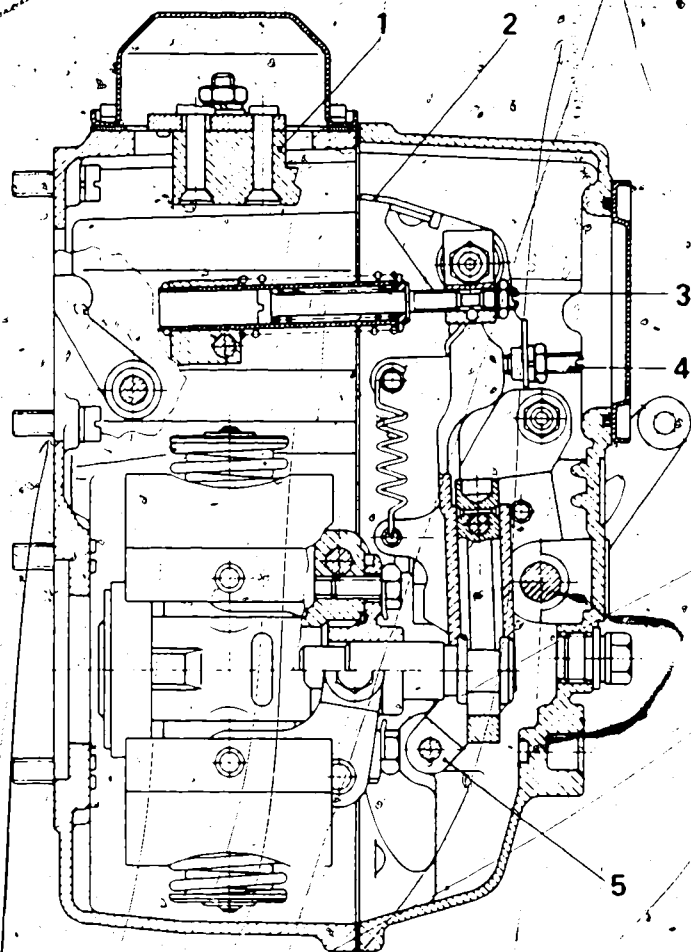

Fig. 3  
1 = Full-load stop (lug)  
2 = Rocker  
3 = Fine adjustment screw  
4 = Rocker screw  
5 = Elbow lever

9.  
Measure idler.  
Test-specification sheet, Section C, Columns 6, 7.  
Note dispersion at upper and lower idler.

**Note:**  
The same testing sequence applies for Test-specification sheet SCA 11.0m1, but different control-rod travel values will result in points 3, 6 with this Test-specification sheet!

M6 (hexagon-socket-head cap screw, length 22)

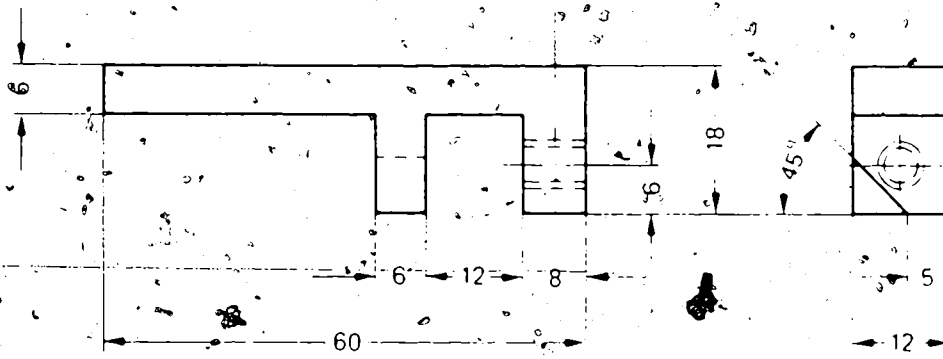

Fig. 4 Clamping piece (user-fabricated)